

Pressure relief valve pilot operated

3.2

Type DB/DBW...L5X

Remote pressure adjusting valve

Type DBT

Sizes 10 to 32
up to 350 bar
up to 650 L/min

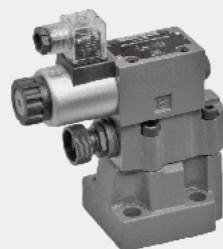

Contents

Function and configuration	02
Symbols	03
Technical data	04
Ordering code	05
Performance curves	06
Unit dimensions	07-09
Remote pressure adjusting valve	10

Features

- For sub-plate mounting
- Porting pattern to DIN 24 340 form E and ISO 6264
- For threaded connection and installation in manifolds
- 5 pressure ratings
- Unloading operation via a built-on solenoid directional valve
- 4 adjustment versions
 - Knob
 - Adjusting bolt with protective cap
 - Lockable knob with scale
 - Knob with scale
- Optional switching shock damping (Only for DBW)

Function and configuration

Types DB and DBW pressure valves are pilot operated pressure relief valves, used to limit (DB) or limit and unload (DBW) pressure via solenoid operation. The pressure relief valves consist of main valve (1) with main spool cartridge (3) and pilot operated valve (2) with pressure adjustment elements.

• Type DB pressure relief valves

The pressure of channel A acts on the main spool (3), meanwhile, pressure is applied via control line (6) and (7) with orifice (4) and (5) on the spring loaded side of the main spool (3) and on the ball (8) in the pilot operated valve(2). If the pressure in channel A rises excess the setting value at the spring (9), the ball (8) opens against the spring (9). As for the internal control forms, signal is given by control oil (10) and (6) supplied by channel A. The oil from the spring loaded side of the main spool (3), via control line (7), orifice(11), and ball (8), then flows into spring chamber (12). External drain - type DB...L5X...Y, oil flows via control line(14) into the tank. In virtue of the orifice (4) and (5), the pressure drop arises at the main spool (3), and the connection from port A to port B is open while theoperational pressure setting maintained stable. The pressure relief valve may unload or shift the different pressure (second rated pressure value) in virtue of external control port X (15).

• Type DBW pressure relief valves

The function of pressure relief valve type DBW is the same with pressure relief valve type DB, the difference is that valve type DBW operates unloading via a built-on directional valve(16).

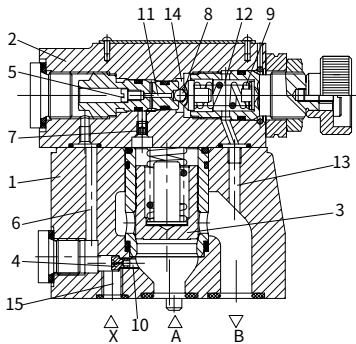

Type DB pressure relief valves

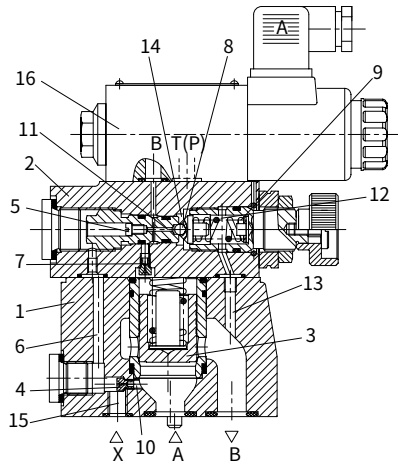

Type DBW pressure relief valves

Function and configuration

• Pressure relief valves with switching shock damping (sandwich), type DBW../..S..R12

Switching shock damping (17), the connection from B2 to B1 opens with delay to avoid peak pressure spikes and decompression in the return line. It is fitted between pilot valve (2) and the directional valve (16).

The relief degree (decompression impact) is determined by the size of the orifice (18).
Orifice Ø1.2mm is recommended.(ordering detail:..R12 ..)

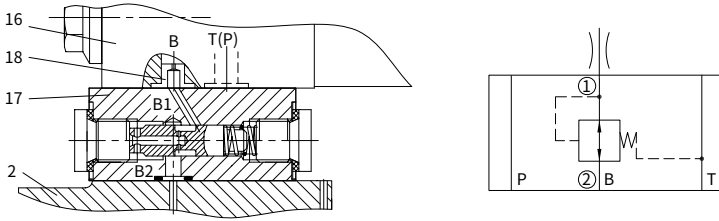

Indication: the directional valve is open

Symbols

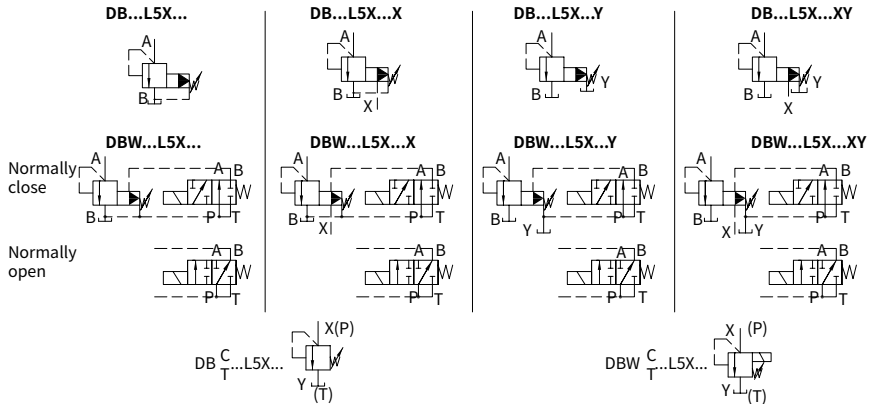

Technical data

Fixing position			Optional				
			DB...10	DB...15	DB...20	DB...25	DB...30
Weight	Sub-plate mounting	DB kg	Approx.3	-	Approx.3.9	-	Approx.5.3
		DBW kg	Approx.4.5	-	Approx.5.4	-	Approx.6.8
		DBC kg	Approx.1.2(Type DBWC add 1.5)kg				
		DBC10 or 30 kg	Approx.1.5(Type DBWC10 and 30 add 1.5)kg				
	Threaded connection	DB..G.. kg	Approx.5.3	Approx.5.2	Approx.5.1	Approx.5.9	Approx.5.8
		DBW..G.. kg	Approx.6.8	Approx.6.7	Approx.6.6	Approx.7.4	Approx.7.3
Switching shock damping		kg	Approx.0.6				
Technical parameters of directional valve			Refer to the solenoid valvetype WE6,normally close use 3WE6A9,normally open use3WE6B9				
Fluid			Mineral oil - suitable for NRB and FRMseal phosphate ester-suitable for FKM seal				
Fluid temperature range		°C	-30 to +80 (NRB seal) -20 to +80 (FKM seal)				
viscosity range		mm ² /s	10 to 800				
Degree of contamination			Maximum permissible degree of fluid contamination: Class 9. NAS 1638 or 20/18/15 , ISO4406				
Max. operating pressure	Port A,B,X,P	bar	350				
	Port T (DB)	bar	315				
Max. back pressure	Port Y DB	bar	315				
	Port Y or T DBW	bar	AC up to 160, DC up to 210				
Max. setting pressure		bar	50;100;200;315;350				
Min. setting pressure		bar	Interrelated with Q(refer to the curve)				
Sizes			10	15	20	25	30
Max. flow-rate	sub-plate mounting	L/min	250	-	500	-	650
	threaded connection	L/min	250	500	500	500	650

Ordering code



Without directional valve= No code
 With directional valve=W

Pressure relief valve, pilot operated = No code
 Pilot operated valve = C
 (without main spool cartridge, no mark for nom. size)
 Pilot operated valve with main spool cartridge = C
 (marked with size 10 or 30)
 Remote pressure adjusting valve = T¹⁾
 (no mark for nom. size)

Nominal size	Connection mode	
	sub-plate mounting	Threaded connection
	Marked	
10	=10	=10
15		=15
20	=20	=20
25		=25
32	=30	=30

For DBW:
 Normally closed =A
 (load breakaway, unload electrified)
 Normally open =B
 (contrary to the above)

Sub-plate mounting = -
 Threaded connection = G

Rotary Knob =1
 Adjusting bolt with protective cap =2
 Lockable knob with scale =3
 Knob with scale =7

Series L50 to L59 =L5X
 (L50 to L59: unchanged installation and connection dimensions)

1) DBT/DBWT are the same as DBC/DBWC, except that the small hole against the main valve hole is plugged.

Further details in clear text

No code = NBR seals
 V = FKM seals

Only for port Y1 in pilot valve of threaded connection or sub-plate mounting
 No code = Inch thread
 2= Metric thread

Only DBW.../...S...:
 R12= orifice Ø1.2 mm in port B of directional valve

Only DBW:
 Z4 = Electrical plug without lamp
 Z5L = Electrical plug with lamp

Only DBW:
 N = With hand override

Only DBW:
 G24 = 24V DC
 W220-50 = 220V AC, 50Hz
 W120-60 = 120V AC, 60Hz
 (Other voltage refer to type WE6)

Only DBW:
 6E= With high performance directional spool valve

No code= Without switching shock damping
 S = With switching shock damping (only with type DBW)

No code= Standard version
 U = Valve for lower opening pressure (not for version without main spool cartridge and not suitable for 350bar)

No code = Pilot oil supply and drain internal
 X = Pilot oil supply external and drain internal
 Y = Pilot oil supply internal and drain external
 XY = Pilot oil supply and drain external

5 = Pressure adjustable up to 50 bar
 10 = Pressure adjustable up to 100 bar
 20 = Pressure adjustable up to 200 bar
 31.5 = Pressure adjustable up to 315 bar
 35 = Pressure adjustable up to 350 bar

Notes:

- The pilot relief valves may have lower starting pressure and higher flow, but have higher internal leakage, If lower leakage is required, such as safety valve, it is recommended to choose direct operated pressure relief valves, DBD type.
- The integrative performance of pilot relief valves with 'U' is not good as the standard version, except lower opening pressure.

Performance curves (Measured at $\vartheta_{oil} = 40^{\circ}C \pm 5^{\circ}C$, using HLP 46)

The characteristic curves are measured with external pilot oil drain at zero pressure. With internal pilot oil drain, the inlet pressure at port B should be added to the value presented as curves.

Inlet pressure in relation to the flow-rate

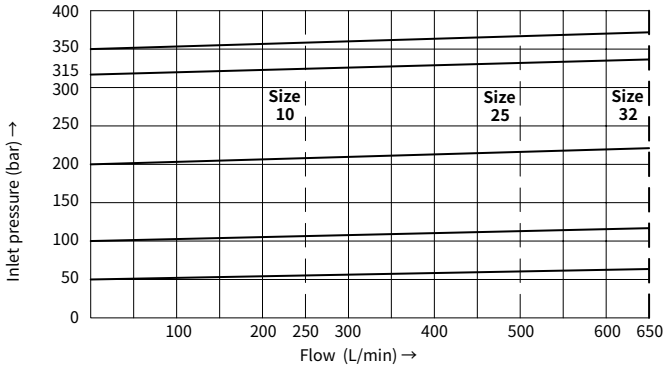

Minimum setting pressure and bypass pressure in relation to the flow-rate!
 · Standard version

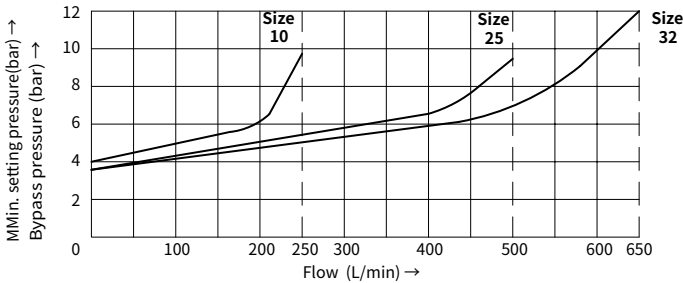

Minimum setting pressure and bypass pressure in relation to the flow-rate!
 · Version "U"

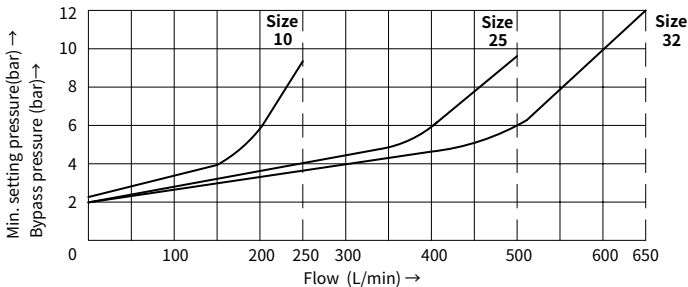

Unit dimensions

(Dimensions in mm)

• Threaded connection

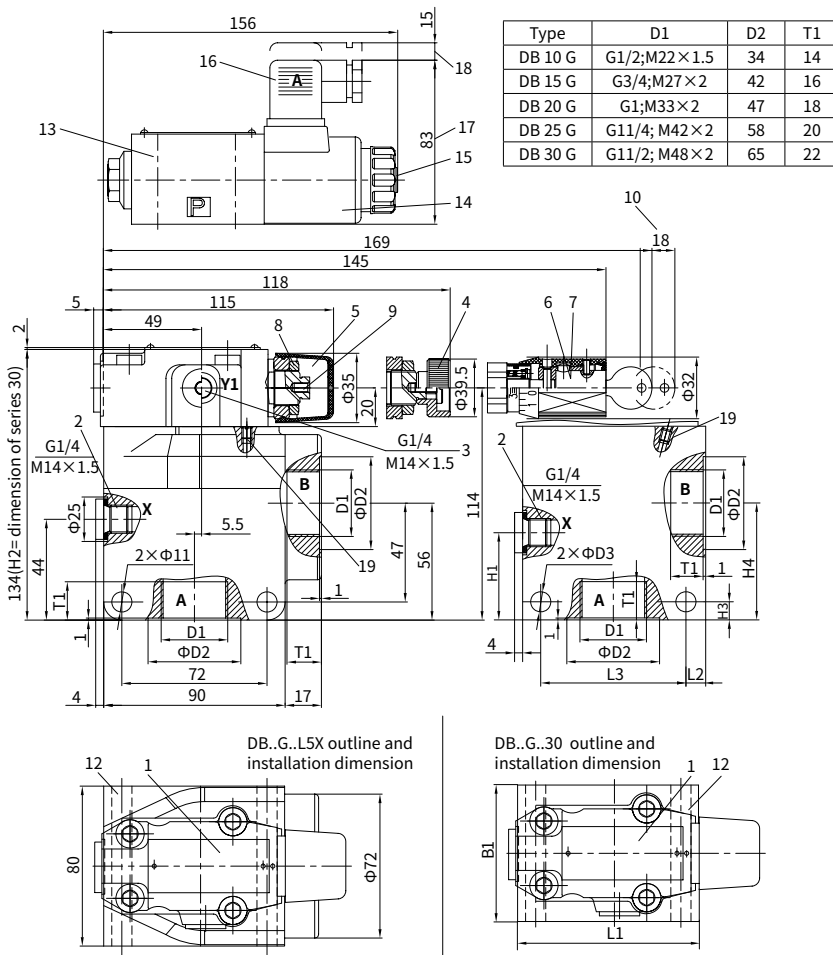

Note:
On threaded connection valve, series L5X and series 30 have different connection dimensions. If series 30 valves need to be replaced by series L5X ones, the pitch of installation holes and the position of external tapping shall be changed.

Outline and installation dimension of series 30 threaded connection valve:

Type	B1	D3	H1	H2	H3	H4	L1	L2	L3
DB 10 G	63	9	27	125	10	62	85	14	62
DB 15 G						57			
DB 20 G						57			
DB 25 G	70	11	42	138	13	66	100	18	72
DB 30 G									

Unit dimensions

(Dimensions in mm)

• With main spool valve (DBC10 or 30) or without main spool valve (DBC, DBT)

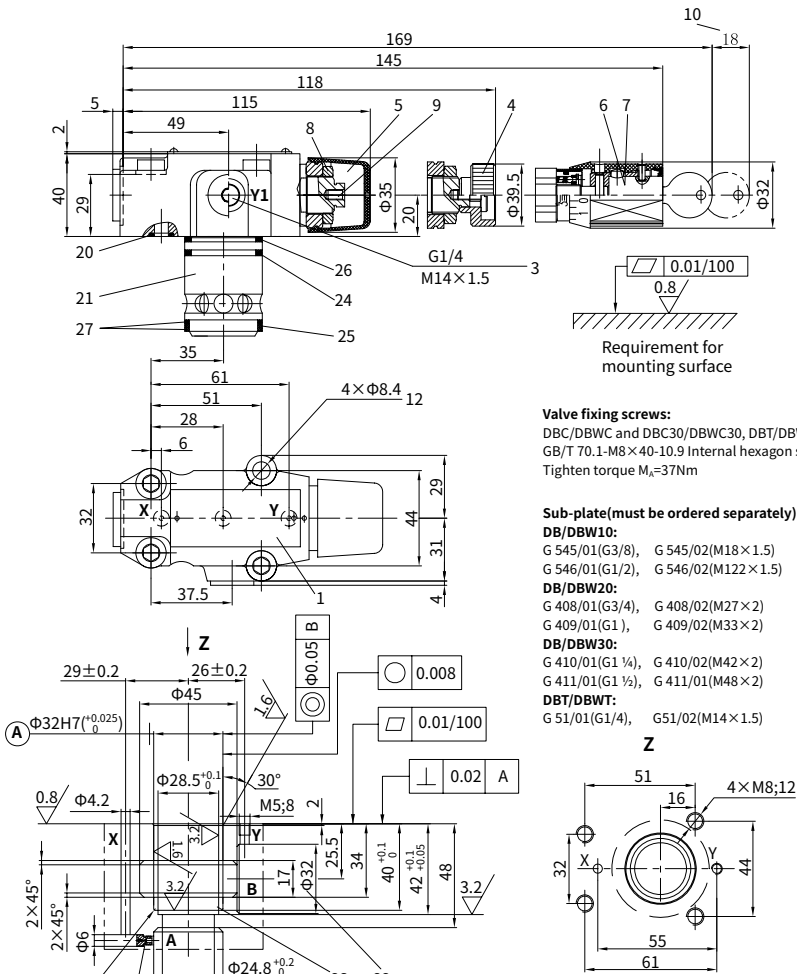

Valve fixing screws:
 DBC/DBWC and DBC30/DBWC30, DBT/DBWT:
 GB/T 70.1-M8×40-10.9 Internal hexagon screw
 Tighten torque $M_t=37Nm$

Sub-plate(must be ordered separately):
DB/DBW10:
 G 545/01(G3/8), G 545/02(M18×1.5)
 G 546/01(G1/2), G 546/02(M122×1.5)
DB/DBW20:
 G 408/01(G3/4), G 408/02(M27×2)
 G 409/01(G1), G 409/02(M33×2)
DB/DBW30:
 G 410/01(G1 ¼), G 410/02(M42×2)
 G 411/01(G1 ½), G 411/01(M48×2)
DBT/DBWT:
 G 51/01(G1/4), G 51/02(M14×1.5)

- 1 Nameplate
- 2 Port X for external pilot oil supply
- 3 Port Y for external pilot oil drain
- 4 Adjustment element "1"
- 5 Adjustment element "2"
- 6 Adjustment element "3"
- 7 Adjustment element "7"
- 8 Lockable nut S=24
- 9 Internal hexagon screw S=10
- 10 Space for drawing the key
- 11 Locating pin
- 12 Valve fixing hole
- 13 Directional valve, size6
- 14 Solenoid "a"
- 15 Hand override "N" button, optional
- 16 Plug-in connector Z4
- 17 Valve dimension with standard solenoid A
- 18 Space required to remove plug-in connector
- 19 Plugged not for internal pilot oil drain
- 20 O-ring 9.25×1.78
- 21 Main spool cartridge
- 22 The Ø32 bore may connect the Ø45 bore at any position. Please take care that the connection hole X and the fixing holes are not damaged.
- 23 Back-up ring and O-ring must be inserted into this bore before assembling the main spool.
- 24 O-ring 28×1.8
- 25 O-ring 27.3×2.4
- 26 O-ring 28×2.65
- 27 Back-up ring 28.4×32×0.8
- 28 Flow controller must be ordered separately

Remote pressure adjusting valve

• Ordering code

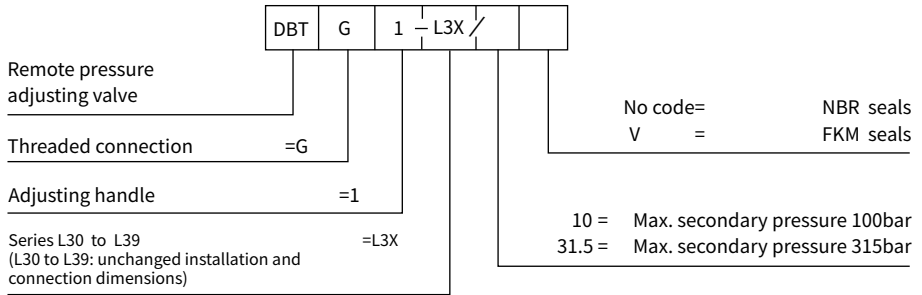

03

• Symbol

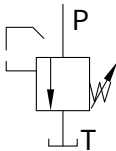

• Connection dimension

