

Splitter gearbox SZ mounted in a frame bracket, permits the assembly of double pumps on the same power take off.

Splitter gearbox SZ provides unlimited freedom to combine pumps with different size flows.

Splitter gearbox SZ is available with gear ratio 1:1.18 or 1:1.54 which gives a corresponding reduction in pump size or additional flow.

Other advantages of splitter gearbox SZ:

- Suitable for all Sunfab pumps with DIN flange.
- Can be mounted horizontally or vertically.

Type		SZ 118	SZ 154
Gear ratio		1:1.18	1:1.54
Max. continuously input torque	Nm	700	700
Max intermittent input torque	Nm	1000	1000
Max continuously torque/pump output	Nm	300	230
Max intermittent torque/pump output	Nm	420	320
Weight	kg	12.3	12.3
Lubrication oil, intermittent operation	l	0.5	0.5

Subject to design alteration

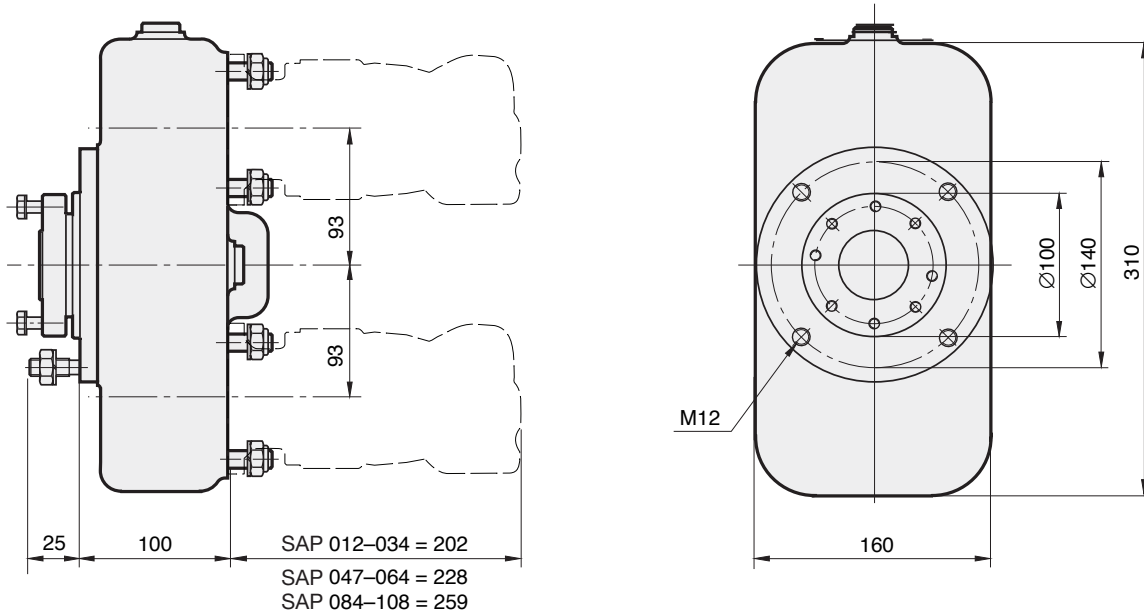

With intermittent operation the gearbox should be filled with 0.5 litres of hypoid oil. Circulation lubrication is required with continuous operation to ensure cooling.

Intermediate shaft connection

The flange for the drive shaft fits directly on Spicer 1300 (B2). Adaptation for other drive shafts is done using the adapter flange, see SUNFAB's accessory catalogue.

The gearbox can also be equipped with an outgoing intermediate shaft on an optional pump output. An adapter is required for this. For component parts see the accessory catalogue.

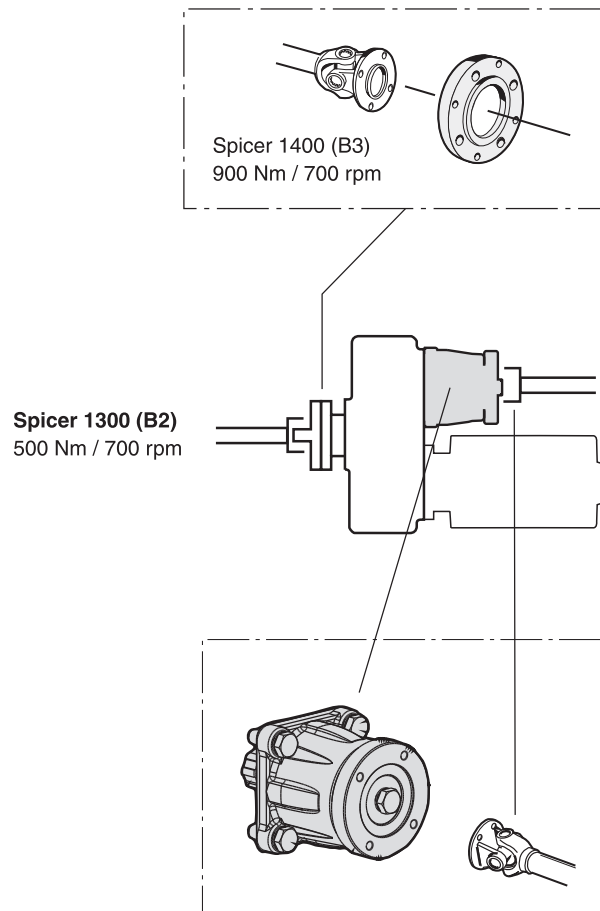

Sunfab reserves the right to make changes in design and dimensions without notice. Printing and typesetting errors reserved.
 © Copyright 2015 Sunfab Hydraulics AB. All Rights Reserved.