



PUMP SCPD 56/26 DIN BY-PASS

INSTRUCTION MANUAL

THANK YOU FOR CHOOSING SUNFAB

You have chosen SCPD 56/26 DIN, a dual flow pump with differentiated flow suitable for combination vehicles with high power take off ratio and high output speeds. Compact design and easy installation makes SCPD 56/26 one of the mainstays for powerful, trouble free hydraulic systems

REMEMBER

A trouble-free hydraulic system is created using selected components and correct installation. Consequently, follow the instructions in this manual, which includes checking the power take off, tank design, hose dimensions, installation and start up. Failure to carry out the manufacturer's installation conditions will invalidate the warranty.

INSTALLATION REQUIREMENTS

POWER TAKE-OFF

- Pump mounting: Spline shaft DIN 5462 / ISO 14.
Mounting flange ISO 7653-D.
- The power take off can be engine, flywheel or gearbox mounted
- The output speed of the power take off must not exceed the pump's max speed, relieved = 2700 rpm
- The permitted torque output on the power take off must be higher than the pump shaft's torque at maximum pressure
- The power take off's direction of rotation must correspond with the selected pump, which is supplied in left-hand (L) or righthand (R) designs

NOTE! The cover must not be turned to change the direction of rotation.

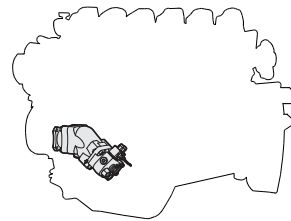

200/200 bar	$178 + 83 = 261 \text{ Nm}$
300/300 bar	$267 + 124 = 391 \text{ Nm}$
400/400 bar	$356 + 165 = 521 \text{ Nm}$

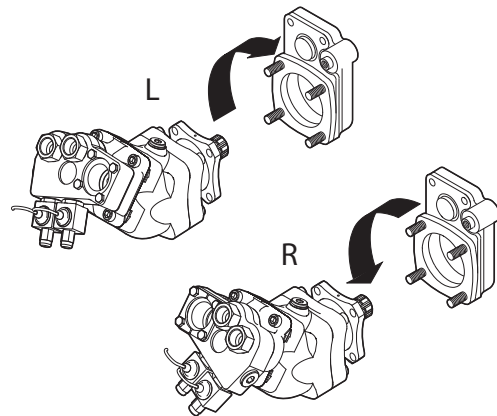

INSTALLATION REQUIREMENTS (Continued)

OIL TANK

The design of the tank is important so that air bubbles are not drawn into the pump and on into the system. Here are two recommended designs:

1. Air bubbles from the return oil are guided by the oil flow up to the oil surface (venting area) via an oil pipe mounted at the bottom of the tank. Another option, yet not as reliable, is a tank with a solid baffle plate as shown in the middle picture.
2. Eventual drainage hoses is connected close to the bottom, as far as possible from the suction connection.
3. Large return filter corresponding to 4 x the pump flow.
4. Separate air filter, which is fitted protected from water and dirt.
5. Suction connection close to or in the bottom of the tank on the opposite side to the return filter.
6. The net volume of the tank should be at least 1.5 x the pump flow and positioned so that the oil level lies above the pump.

A traditional tank fitted with a baffle plate with holes is not recommended as this does not deaerate the oil satisfactorily.

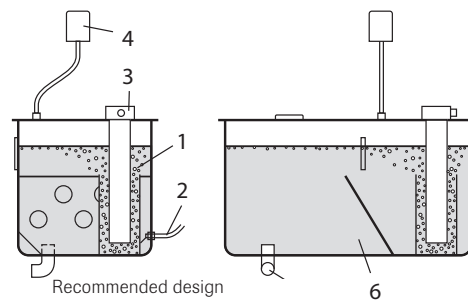

Recommended design

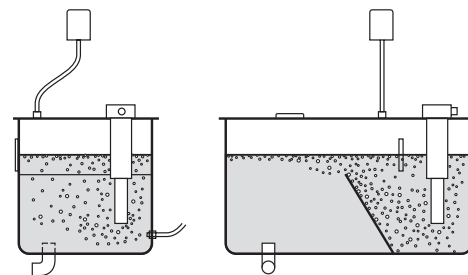

Optional design, solid baffle plate

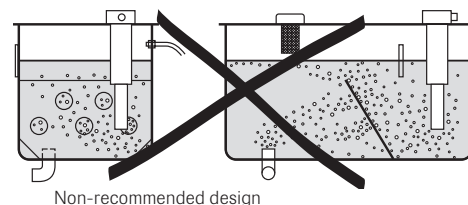

Non-recommended design

SUNFAB OIL TANK

This tank is included in the Sunfab range of accessories. It incorporates the latest advances in tank design to give trouble-free operation. The tank is available in two material options: stainless steel and aluminium.

PRESSURE RELIEF AND CHECK VALVES

The hydraulic system must be equipped with a pressure relief valve for each circuit if the flow is used for different functions.

RECOMMENDED LINE SIZE (d)

All dimensions, internal diameter

Max flow	120 lit/min	160 lit/min
Max speed	1 470 rpm	1 850 rpm
Suction hose	50 mm (2")	64 mm (2½")
Shut off valve	50 mm (2")	64 mm (2½")
Return hose	32 mm (1¼")	38 mm (1½")
Pressure hose	19 mm (¾")	19 mm (¾")

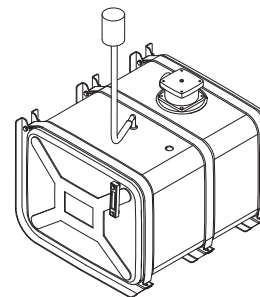

Important by installation!

Engine mounted power take-off requires an internal diameter of 64 mm (2.5") on suction hose and connection.

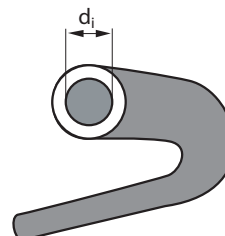

If the suction line is more than 2 m long the internal diameter must be increased by 10 mm for each meter extension.

INSTALLATION REQUIREMENTS (Continued)

HYDRAULIC OILS

Quality:

- Mineral oil
Use a high quality oil whose technical properties conform, as a minimum, to the following requirements:
ISO type HM VG 32-68 depending on the ambient air temperature.
Alternatively DIN 51524-2 HLP.
- Environment oil
Use synthetic ester that conforms to the same technical requirements as the standards above.

Oil filling - Oil changing:

- New hydraulic oil has a too high impurity level. Filling should therefore be done with the help of a filter unit or through the oil tank's return filter.
- Do not mix oil of a different quality, viscosity or brand. This will impair the technical properties of the oil.

Viscosity:

The viscosity of the hydraulic oil drops (the oil becomes thinner) when the temperature rises. An ideal choice is an oil with a high viscosity index (VI). A higher VI gives less viscosity variation when the temperature changes

- At a viscosity higher than 1500 cSt (limit for cold start) the pump cannot suck in oil
- At a viscosity lower than 10 cSt the lubrication capacity is insufficient. System efficiency will also be impaired
- When there is a risk of the oil temperature in oil tank to exceed 60 °C, an oil cooler must be used

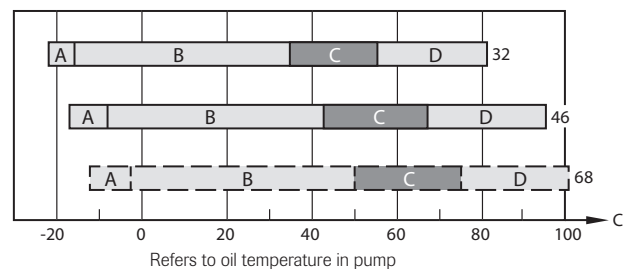
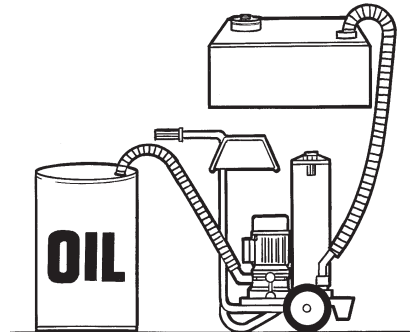

E.g. Hydraulic oil 32: The designation "32" denotes the viscosity is 32 cSt at 40 °C. Lowest start temperature is -23 °C and highest working temperature 82 °C. Ideal working temperature is 35 - 55 °C.

- A** = The hydraulic system can be started but not loaded. Only circulation pumping at idling speed 1500-700 cSt.
- B** = The system can be loaded 700-40 cSt.
- C** = Ideal working range 40-20 cSt.
- D** = Highest recommended operating temperature 20-10 cSt.

NOTE! The diagram concerns hydraulic oil with viscosity index VI ≈ 180



INSTALLATION REQUIREMENTS (Continued)

FILTERING:

To invest in cleanliness is worthwhile:

- Halving of the amount of particles doubles component life
- Halving of the amount of particles reduces the degree of malfunction by half.

To conform to most market demands on operating reliability and life span the impurity level of the oil should correspond to class 18/16/13 as set out in ISO 4406.

Consequently, the hydraulic system is equipped with a return filter and air filter with a degree of filtration equal to 10 µm absolute.

Furthermore, the hydraulic system should be equipped with a pressure filter if necessary.

CHANGING THE FILTER:

First change after 50 hours of operation. Then whenever the filter pressure indicates too high a pressure at the normal operating temperature for hydraulic oil.

A good rule is to change the air filter at the same time.

Contamination level 18/16/13

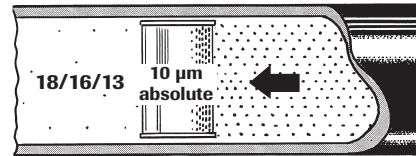

Max 64,000 particles > 5 µm/100 ml.
Max 8,000 particles > 15 µm/100 ml.



After changing the filter, run with the lowest possible flow for at least 5 minutes to ensure the filter functions.

INSTALLATION

Installing By-Pass valve

The By-Pass valve can be installed with the solenoids in two positions depending on the installation space available. Note that the plug (1) must swap ports depending on which alternative is selected.

Clean the contact surfaces. Install the valve with the necessary seals and banjo bolts. The screws are installed in conjunction with the suction connection.

If the space available does not permit the valve to be installed directly against the pump it can be installed on the hose.

Cooling pipe/drainage pipe

Separate cooling pipe/drainage pipe should be installed when the pump is installed on an engine power take-off. Cooling pipe/drainage pipe must be installed when the control valve is the "closed center" type or when the pumped flow pressure is 0.15 MPa or higher.

The line must be routed directly from the By-Pass valve to a connection below the oil level of the tank.

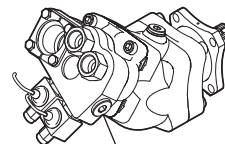
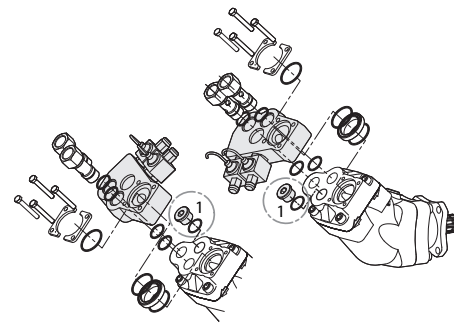

Connection G $\frac{3}{4}$
to cooling pipe/
drainage pipe.
80 Nm



INSTALLATION (Continued)

Pump installation

Lubricate the splined shaft before installation using assembly paste intended for spline joints, e.g. Molykote G Rapid plus, or the like. Do not hit the gear wheel/drive disc.

Use a M12 stud bolt and sleeve when assembling the gear wheel.
Use a M12 stud bolt and washer when assembling the drive disc.
Secure the gear wheel using a circlip or M12 bolt and locking fluid.
Secure the O-ring and fit the pump on the power take-off.
The manufacturer of the power take-off may have different requirements.

Connections

Secure the O-ring and tighten the suction connection bolts crosswise.
Tighten the hose using two heavy-duty hose clips. To maintain the speed characteristics do not use a strainer on the SCPD-pump. Use pressure connections with flat seals against the pump for optimal strength. Do not use connections with tapered threads.

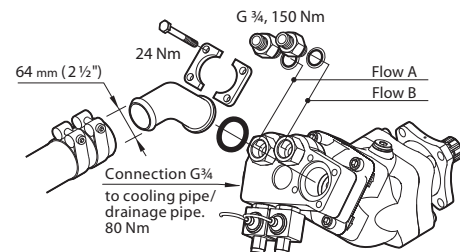
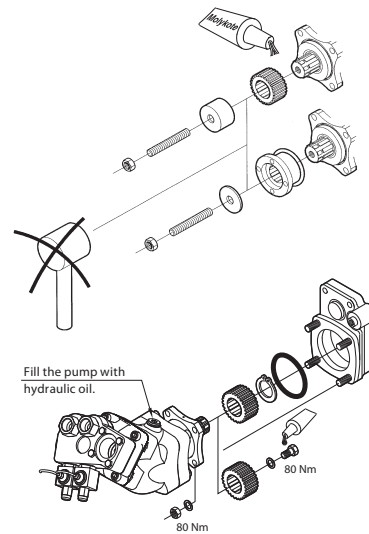

Tank location and hose routing

The tank should be positioned as high and as close to the pump as possible in order to create good suction conditions for the pump. The suction pipe is routed so that air pockets cannot form, to prevent cavitation and noise.

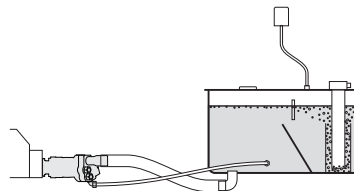

The pump can be installed in 4 positions with the angle upwards, downwards or to the side. When the angle is to the side it is an advantage if the pump can be twisted so that the suction connection is highest.

Electrical installation

Switch off the master switch and the battery. When it is necessary to change the direction of the cables: Slacken off the top nut on the solenoid coil. Route the cables to the switch and the battery. Tighten the nut.

Solenoid voltage 24 V
Current/solenoid 0.52 A

Start up

Start and run the pump unloaded at idling speed and allow the hydraulic oil to circulate through the hydraulic system for at least five minutes before the system's functionality is tested.

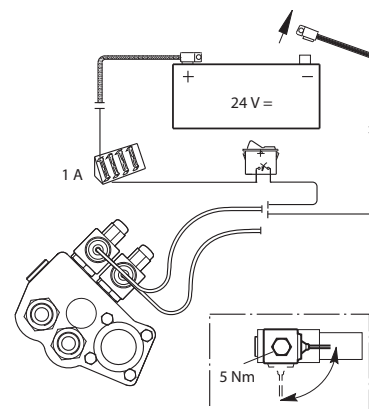



TROUBLESHOOTING

Measures with malfunctioning hydraulic system

Fault	Troubleshooting	Cause	Action
The equipment works jerkily.	Check whether the flow in the pressure hose from the pump pulsates. Oil spots on the pump and suction hose can indicate an air leakage. Check the oil level in the tank. Check whether the oil foams.	<ol style="list-style-type: none"> 1. Pump not vented after installation. 2. Airleakage on the suction hose or pump. 3. Oil level too low. 4. Not optimal designed tank for separation of air from the oil. 5. Oil tank with too small air venting area. 	<ol style="list-style-type: none"> 1. Vent the pump. 2. Repair the air leakage. 3. Fill with oil. 4. Replace the return filter with an oil pipe or tank with solid baffle plate. 5. Change to a tank with a greater air venting area.
The equipment works jerkily when starting and at a high pump speed.	Check whether the pump cavitates. This is noticeable through flow pulsations and noise from the pump stopping when the speed is lowered.	<ol style="list-style-type: none"> 1. Too small diameter on the suction hose. 2. Crushing or restriction of the suction hose. 3. Oil too thick. 4. Underpressure in the oil tank. 	<ol style="list-style-type: none"> 1. Change to a suction hose with a larger diameter. 2. Remove the restriction. 3. Change to an oil with a lower viscosity. 4. Change the air filter.
The oil has an abnormally high temperature.	Run the pump unloaded at working speed and measure the counter pressure. Connect a pressure gauge to the pressure hose close to the pump. The pressure must not exceed 2 MPa. Check whether the pressure rises to the correct value when a function is run towards the stop.	<ol style="list-style-type: none"> 1. Too small a diameter or restriction in the pressure or return hoses. 2. Clogged pressure or return filter. 3. Oil flow too great. 4. Pressure relief valve tripped at too low a pressure. 5. Oil too thin. 6. Oil tank too small. 7. Oil level too low. 8. High continuous power output. 	<ol style="list-style-type: none"> 1. Change to hoses with a larger diameter; rectify the restriction. 2. Replace the filter. 3. Lower the speed or change to a smaller pump. 4. Adjust the valve or replace if necessary. 5. Change to an oil with a higher viscosity. 6. Change to a larger oil tank. 7. Fill with oil. 8. Fit an oil cooler.
The equipment has a lack of power.	Check whether the pressure rises to the correct value when a function is run towards the stop.	<ol style="list-style-type: none"> 1. Pressure relief valve tripped at too low a pressure. 2. Defective directional control valve. 	<ol style="list-style-type: none"> 1. Adjust the valve or replace if necessary. 2. Replace the directional control valve.
The equipment runs abnormally slowly when loaded.	Connect a flow meter close to the pump. Check the flow. <ol style="list-style-type: none"> 1. The correct flow is obtained when loaded. 2. Abnormally low flow obtained when loaded. 	<ol style="list-style-type: none"> 1. Pressure relief valve tripped at too low a pressure. 2. Worn pump. 	<ol style="list-style-type: none"> 1. Adjust the valve or replace if necessary. 2. Replace the pump.
Noise from the pump.	<ol style="list-style-type: none"> 1-5. Check whether the pump cavitates. This is indicated by the noise stopping when the speed drops. Check whether the noise propagates in the hydraulic system. 6. Check whether the noise can be heard at all speeds. 	<ol style="list-style-type: none"> 1. Too small diameter on the suction hose. 2. Crushing or restriction of the suction hose. 3. Oil too thick. 4. Underpressure in the oil tank. 5. Worn pump. 	<ol style="list-style-type: none"> 1. Change to a suction hose with a larger diameter. 2. Remove the restriction. 3. Change to an oil with a lower viscosity. 4. Change the air filter. 5. Replace the pump.
Oil leakage from the pump.	Localise the oil leakage.	<ol style="list-style-type: none"> 1. Leakage from the suction connection. 2. Leakage from the shaft seal. 3. Leakage from the plugs/fittings. 	<ol style="list-style-type: none"> 1. Replace the O-rings and tighten the hose clips. 2. Replace the shaft seals. 3. Replace the plugs/fittings and tighten carefully (15 Nm).
The pump shakes (intermediate shaft assembly).	Check whether the pump shakes, despite the flow not pulsating, i.e. the attachment does not jerk.	<ol style="list-style-type: none"> 1. Play on intermediate shaft. 2. Incorrect joint angle on intermediate shaft. 3. Imbalance on intermediate shaft. 4. The universal joints are not in line with each other. 	<ol style="list-style-type: none"> 1. Replace the intermediate shaft. 2. Ensure that the spindle on the power take off and pump shaft are parallel. 3. Rectify the intermediate shaft. 4. Loosen and turn the spline coupling so that the universal joints are aligned with each other.



If oil leakage has occurred via a damaged shaft seal, ensure that no hydraulic oil has entered the gearbox!

EMERGENCY OPERATION OF THE BY-PASS VALVE

If it is necessary to run a hydraulic function as an emergency operation during a power cut, the pump flow can be started manually by screwing in the By-Pass valve setting screw.

For safety reasons the pump must not be running during the intervention.

Do as follows:

1. Lift off the red protective cap on the solenoid housing
2. Slacken off the nut
3. Screw in the adjusting screw until the pin bottoms
4. Lock the adjusting screw with the nut

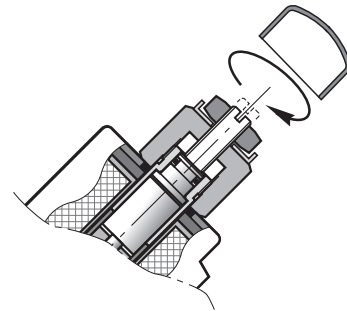

The valve is now affected and oil can be pumped into the hydraulic system.

After emergency operation is completed the adjustment screw is reset to the original position, locked and the protective cap reinstalled.

TECHNICAL DATA SCPD 56/26 DIN

		I/min
Nominal oil flow A+B	600	$33.5 + 15.5 = 49$
at pump speed	1200	$67.0 + 31.0 = 98$
rpm	1800	$100.5 + 46.5 = 147$

Displacement A+B	cm ³ / rev	56 + 26
Max pump speed A+B	rpm	1850
Max pump speed A	rpm	1850
Max pump speed B	rpm	2200
Max pump speed, relieved	rpm	2700
Max working pressure	Bar	400
Weight without valve	kg	18
Weight with valve	kg	22.5
Tare-weight torque without valve	Nm	21
Tare-weight torque with valve	Nm	25.5

		200 Bar	300 Bar	400 Bar
Nominal power at pressure	600	$11.2 + 5.2 = 16.4$ kW	$16.8 + 7.8 = 24.6$ kW	$22.3 + 10.3 = 32.6$ kW
and pump speed	1200	$22.3 + 10.3 = 32.6$ kW	$33.5 + 15.5 = 49.0$ kW	$44.7 + 20.7 = 65.4$ kW
rpm	1800	$33.5 + 15.5 = 49.0$ kW	$50.3 + 23.3 = 73.6$ kW	$67.0 + 31.0 = 98.0$ kW

		200 Bar	300 Bar	400 Bar
Nominal torque on pump shaft		$178 + 83 = 261$ Nm	$267 + 124 = 391$ Nm	$356 + 165 = 521$ Nm
at different pressures				

Direction of rotation supplied in right or left-hand design

**WARNING**

When the pump is running:

1. Do not touch the pressure hose
2. Watch out for rotating parts
3. The pump and hoses may be hot

*Sunfab reserves the right to make changes in design and dimensions without notice. Printing and typesetting errors reserved.
© Copyright 2015 Sunfab Hydraulics AB. All Rights Reserved.*