

4.3

# Throttle and throttle check valve

## Type DV(P)/DRV(P)...10

Sizes 6 to 30  
Up to 350bar  
Up to 375 L/min



### Contents

Function and configuration	02
Symbols	02
Ordering code	03
Technical data	03
Characteristic curves	04
Unit dimensions	05-08

### Features

- For direct in-pipe mounting
- For control panel mounting
- Threaded connection
- Good repeatability of set values due to color scale
- Variant, optional:

## Function and configuration

Throttle valve of type DV, DVP and check valve of type DRV, DRVP are flow control valves to adjust movement speed of actuators simply and exactly. These valve can also be used as shut-off valve when completely shut.

The scale of triangle shows how large the flow is (The larger the triangle is and the greater the flow is). At the same time, for resetting again, it can be restored to the preset position.

Type DV, DVP

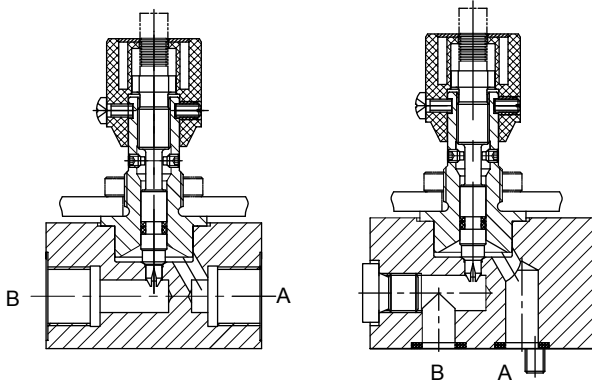

Type DRV, DRVP

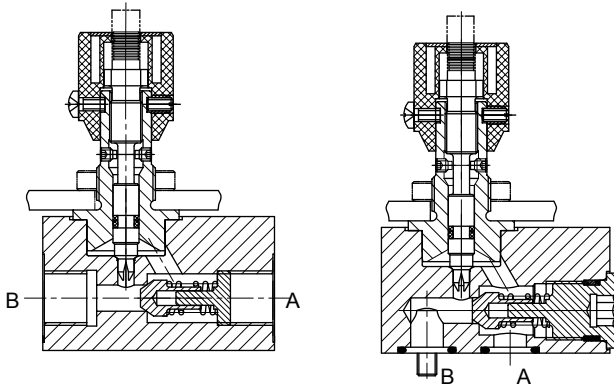

## Symbols

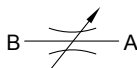

Type DV, DVP

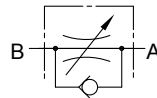

Type DRV, DRVP

## Ordering code

					1	—	10	/			*
Throttle valve =DV											
Throttle check valve=DRV											
Threaded connection=No code											
Sub-plate mounting = P											
Nominal size 6 =6											
Nominal size 8 =8											
Nominal size 10 =10											
Nominal size 12 =12											
Nominal size 16 =16											
Nominal size 20 =20											
Nominal size 25 =25											
Nominal size 30 =30											

Further details in clear text

No code =	NBR seals
V =	FKM seals
Threaded connection	
No code=	Inch thread
2 =	Metric thread
10=	10 Series
1=	Steel valve body
- =	For direct in-line mounting
S =	For Control panel mounting

04

## Technical data

Size		6	8	10	12	16	20	25	30	
Max.Operating pressure	bar	350								
Check valve cracking pressure	bar	0.5								
Weight	Type DV	kg	0.12	0.53	0.7	0.9	1.5	2.5	3.3	3.8
	Type DVP		0.25	0.7	1.0	1.3	2.6	4.3	8.3	11.2
	Type DRV		0.13	0.6	0.7	0.9	1.5	3.1	4.1	5.3
	Type DRVP		0.26	0.7	1.0	1.4	2.7	4.7	8.8	12.2
Fluid		Mineral oil; phosphate ester								
Fluid temperature range	°C	-20 to +80								
Viscosity	mm <sup>2</sup> /s	2.8~500								
Installation position		Optional								
Degree of contamination		Maximum permissible degree of fluid contamination: Class 9. NAS 1638 or 20/18/15, ISO4406								

## Characteristic curves (Measured at $\theta_{oil}=40^{\circ}C \pm 5^{\circ}C$ , using HLP46)

**Flow direction: A to B** relation of differential pressure  $\Delta P$  to flow  $Q$  in constant throttle position

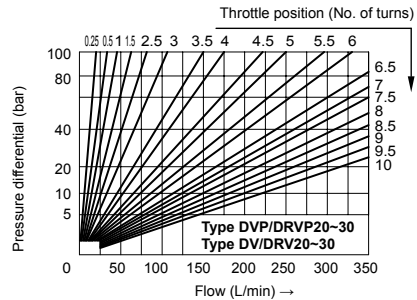
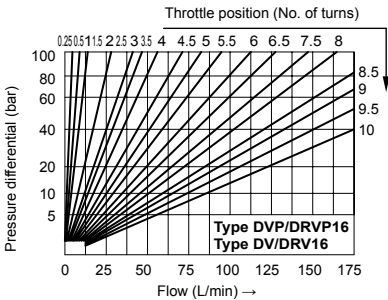
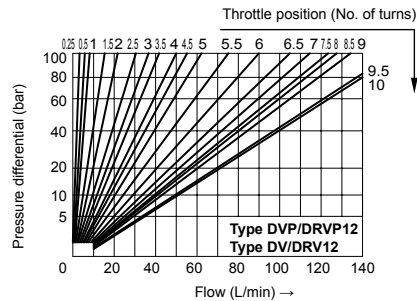
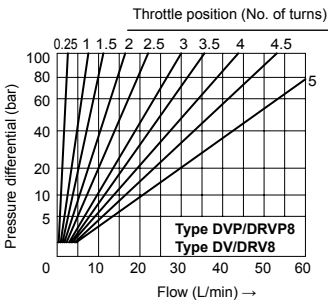
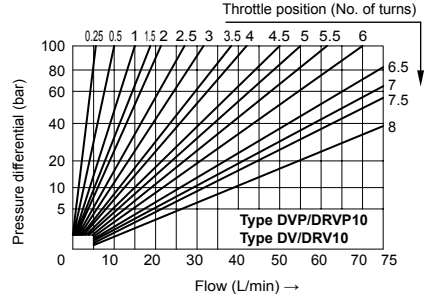
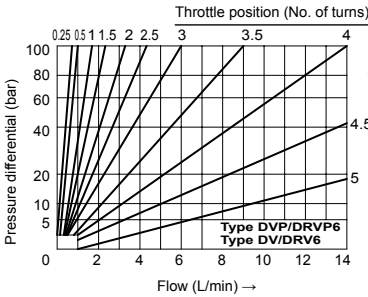

### Type DRV

**Flow direction: B to A** P-Q curve of Free flow via open check valve

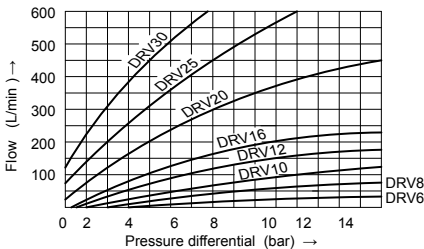

## Unit dimensions

### • Threaded-connection (Type DV)

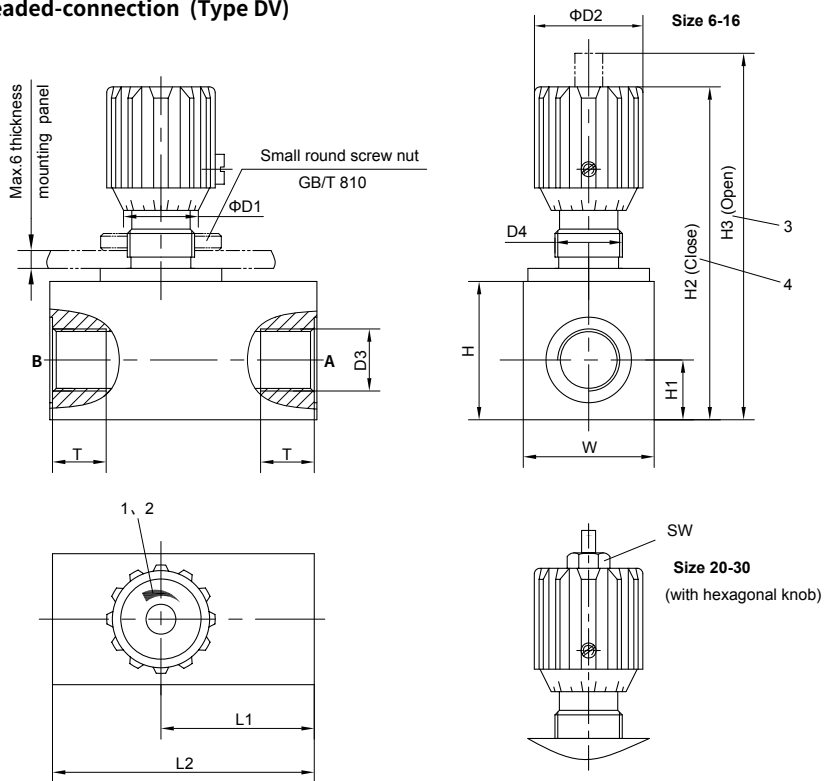

- 1 Flow increases with anti-clockwise rotation
- 2 Flow reduces with clockwise rotation

- 3 Throttle fully opens
- 4 Throttle closes

Size	W×H	$\Phi D1$	$\Phi D2$	D3		D4	H1	H2	H3	L1	L2	SW	T
6	20×20	15	24	G1/8	M10×1	M12×1.25	10	64	68	19.5	39		9
8	34×30.5	20	29	G1/4	M14×1.5	M18×1.5	12.5	83	90	32.5	63.5		12
10	36.5×38.5	20	29	G3/8	M18×1.5	M18×1.5	16	95	103	33	66		12
12	37×38	26	37.5	G1/2	M22×1.5	M22×1.5	17.5	101.5	109.5	44.5	80		14
16	45×52	26	37.5	G3/4	M27×2	M22×1.5	22.5	124	134.5	44.5			16
20	57×56.5	38	50	G1	M33×2	M36×1.5	26	162.5	178.5	49.5	99	19	18
25	63×66	38	50	G1 1/4	M42×2	M36×1.5	30	167	186	54.5	109	19	20
30	73×76	38	50	G1 1/2	M48×2	M36×1.5	35	177.5	196	54.5	109	19	22

## Unit dimensions

### • Threaded-connection (Type DRV)

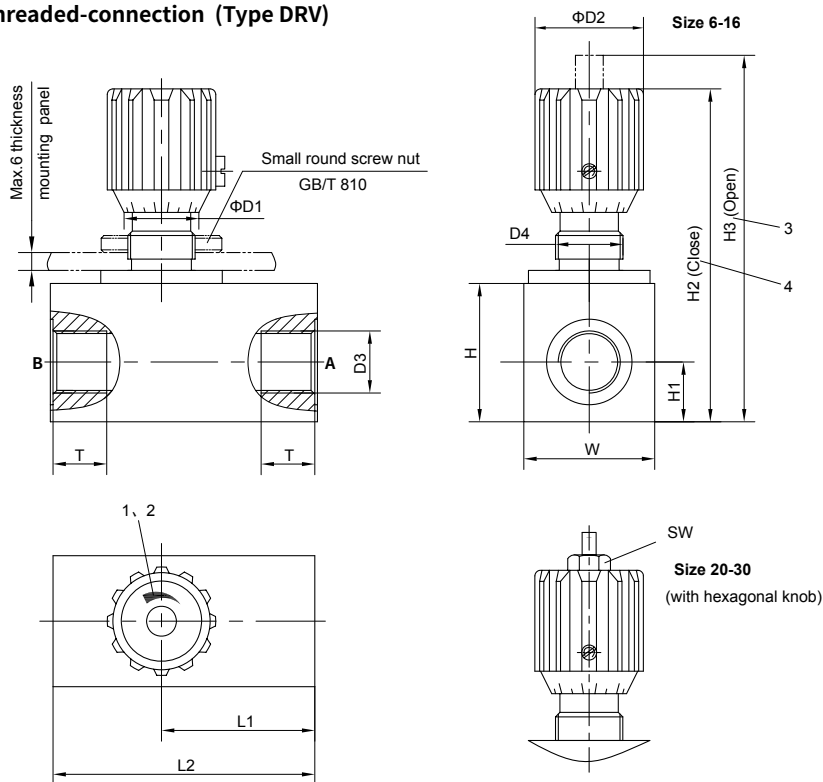

Size	W×H	ΦD1	ΦD2	D3		D4	H1	H2	H3	L1	L2	SW	T
6	20×21	15	24	G1/8	M10×1	M12×1.25	10	65	70	28	46		9
8	34×35	20	29	G1/4	M14×1.5	M18×1.5	15	87	94	38	64.5		12
10	36.5×41	20	29	G3/8	M18×1.5	M18×1.5	16	98	105	45.5	71		12
12	37×42	26	37.5	G1/2	M22×1.5	M22×1.5	17.5	105	113	48	81		14
16	45×54	26	37.5	G3/4	M27×2	M22×1.5	22.5	124	134.5	56.5	89		16
20	57×59	38	50	G1	M33×2	M36×1.5	26	162.5	178.5	80	128	19	18
25	63×70	38	50	G1 1/4	M42×2	M36×1.5	30	170	186.5	98	144	19	20
30	73×80	38	50	G1 1/2	M48×2	M36×1.5	35	180	195.5	105	145	19	22

1 Flow increases with anti-clockwise rotation

2 Flow reduces with clockwise rotation

3 Throttle fully opens

4 Throttle closes

## Unit dimensions

### • Sub-plate mounting (Type DVP)

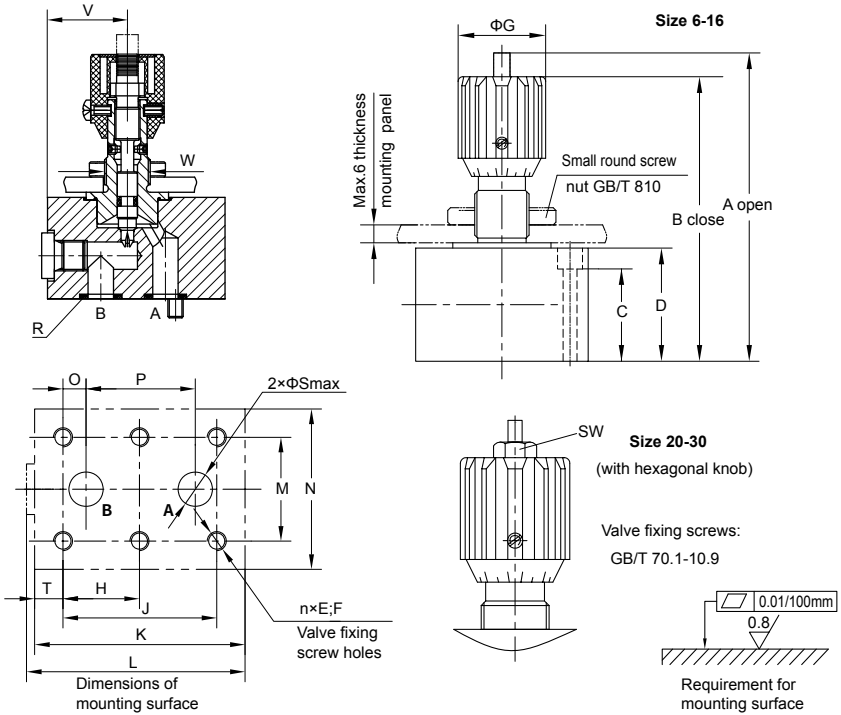

Size	A	B	C	D	n	E	F	G	H	J	K	L	M	N
6	66	61.5	10	18	4	M6	12	24	-	19	38	41	28.5	41.5
8	89.6	82.7	21	30.5	4	M6	12	29	-	35	63.5	67	33.5	46
10	104	96	29.5	40	4	M6	12	29	-	33.5	70	72.3	38	51
12	109	100.5	29	38	4	M6	12	37.5	-	38	80	82	44.5	57.5
16	133	122.3	41	52	6	M8	16	37.5	38	76	104	107	54	70
20	177	161	49	61	6	M8	16	50	47.5	95	127	129	60	76.5
25	185	170	55	68.5	6	M10	20	50	60	120	165	168	76	100
30	195	179	63	79	6	M12	24	50	71.5	143	186	186	92	115

Size	O	P	R	S	T	V	W	SW	Vale fixing screw
6	1.6	16	O-ring 7×1.5	5	9.5	18.5	M12×1.25	-	M6×20
8	4.5	25.5	O-ring 12.3×2.4	8	14.3	31	M18×1.5	-	M6×30
10	4	25.5	O-ring 12.3×2.4	10	17	31.5	M18×1.5	-	M6×40
12	4	30	O-ring 15×2.65	12	21	36.5	M22×1.5	-	M6×40
16	11.4	54	O-ring 19×3	15	14	49	M22×1.5	-	M8×55
20	19	57	O-ring 30×3	20	17	47	M36×1.5	19	M8×60
25	20.6	79.5	O-ring 32×3	25	15	77	M36×1.5	19	M10×70
30	23.8	95	O-ring 34.52×3.53	30	15	85	M36×1.5	19	M12×80

## Unit dimensions

### • Sub-plate mounting (Type DRV(P))

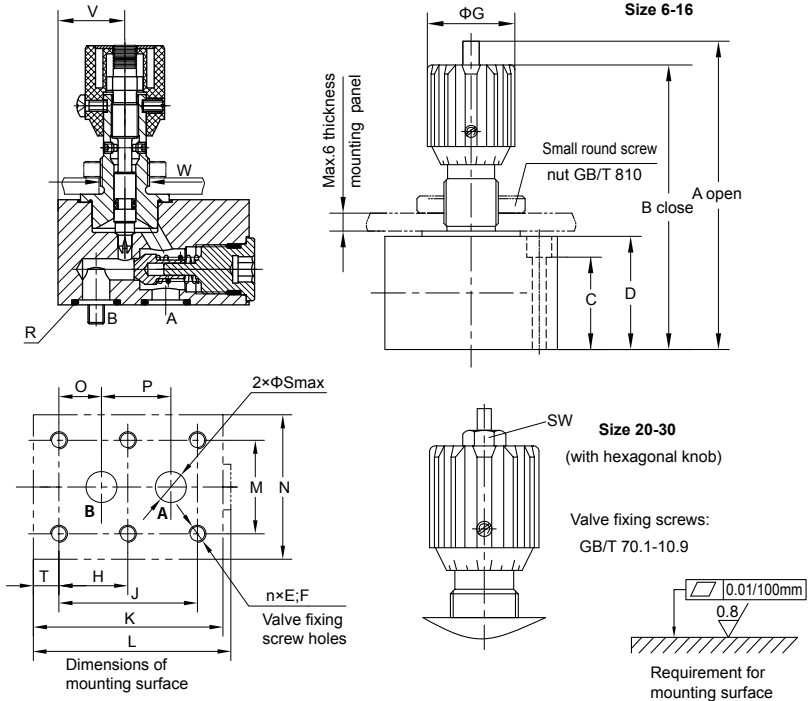

Size	A	B	C	D	n	E	F	G	H	J	K	L	M	N
6	67	62.5	9	19	4	M6	12	24	-	19	41.5	43	28.5	41.5
8	90	83	19	31	4	M6	12	29	-	35	63	67	33.5	46
10	103	95	30	38.5	4	M6	12	29	-	33.5	70	72	38	51
12	112	103.5	29	41	4	M6	12	37.5	-	38	80	84	44.5	57.5
16	132	122	41	51	6	M8	16	37.5	38	76	104	107	54	70
20	176	161	48	60	6	M8	16	50	47.5	95	127	131	60	76.5
25	186	171	55	70	6	M10	20	50	60	120	165	169	76	100
30	195	180	63	79	6	M12	24	50	71.5	143	186	190	92	115

Size	O	P	R	S	T	V	W	SW	Vale fixing screw
6	1.6	16	O-ring 7×1.5	5	6.4	10	M12×1.25	-	M6×20
8	4.5	25.5	O-ring 12.3×2.4	8	9.3	25.8	M18×1.5	-	M6×30
10	4	25.5	O-ring 13.2×2.4	10	10	24.5	M18×1.5	-	M6×40
12	4	30	O-ring 15×2.65	12	21	31.5	M22×1.5	-	M6×40
16	11.4	54	O-ring 19×3	15	14	41	M22×1.5	-	M8×55
20	19	57	O-ring 30×3	20	17	44	M36×1.5	19	M8×60
25	20.6	79.5	O-ring 32×3	25	15	62	M36×1.5	19	M10×70
30	23.8	95	O-ring 34.52×3.53	30	15	72	M36×1.5	19	M12×80