

3.7

# Pilot operated pressure relief valve

## Type ZDB / Z2DB 10V..L4X

Size 10  
up to 315bar  
up to 100 L/min



### Contents

Function and configuration	02
Symbols	02
Ordering code	03
Technical data	03
Characteristic curves	03
Unit dimensions	04-06

### Features

- Sandwich plate valve
- Porting pattern to DIN 24 340 form A and ISO 4401
- For threaded connection, and sub-plate mounting
- 4 pressure ratings
- 6 circuit options
- With one or two pressure relief cartridges
- 4 adjustment elements:
  - Rotary knob
  - Adjustable bolt with protective cap
  - Lockable rotary knob with scale
  - Rotary knob with scale

## Function and configuration

Pressure relief valve types ZDB and Z2DB are pilot operated and sandwich structure. They are used to limit the pressure in a hydraulic system.

They basically consist of the housing (7), together with one or two pressure relief valves cartridges. And the system pressure is set by means of relief valve(4).

At static position, the valves are closed. Pressure in port A acts on the spool (1). Pressure fluid flows through orifice (2) to the spring loaded side of the spool (1) and through orifice (3) to the pilot poppet (6). If the pressure in port A rises beyond the value setting at spring (5), the pilot poppet (6) opens. Fluid can flow from the spring loaded side of spool (1), orifice (3), and channel (8) into port T. The pressure drop moves spool (1) to open the connection from A to T, while the setting pressure at spring (5) is maintained. Pilot oil returns from the two spring chambers via port T externally.

### Type ZDB10VA2-L4X/...

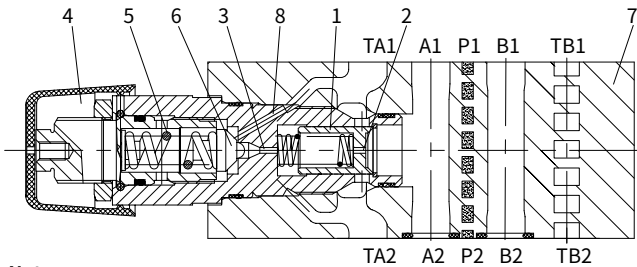

**Notes:**

The pilot relief valves have more internal leakage,  
 If lower leakage is demanded, such as safety valve,  
 it is recommended to choose direct operated pressure relief valves, ZDBD type.

## Symbols

Type ZDB10VA..

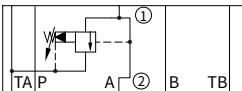

Type ZDB10VB..

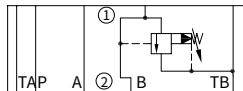

Type ZDB10VP..

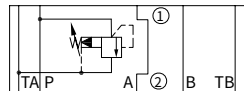

Type ZDB10VT..

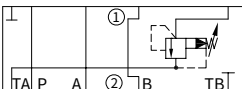

Type Z2DB10VC..

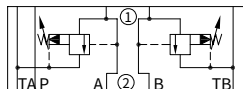

Type Z2DB10VD..

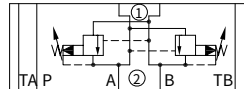

① = valve side    ② = sub-plate side

## Ordering code

	Z		DB	10		- L4X /		★	
Sandwich plate	= Z								Further details in clear text
Only applies to models VC and VD: With 2 pressure relief valve cartridges	= 2								No code = NBR seals V = FKM seals
Pressure relief valve	= DB								5 = Pressure adjustable up to 50bar 10 = Pressure adjustable up to 100bar 20 = Pressure adjustable up to 200bar 31.5 = Pressure adjustable up to 315bar
Nominal size 10	= 10								L4X = Series L40 to L49 (L40 to L49: unchanged installation and connection dimensions)
Relief function from → to:									1 = Rotary knob 2 = Adjustable bolt with protective cap 3 = Lockable rotary knob with scale 7 = Rotary knob with scale
A → TA								=VA	
P → TA								=VP	
TB1 → TA2								=VT	
B → TB								=VB	
A → TA and B → TB								=VC	
A → B and B → A								=VD	

## Technical data

Fluid		Mineral oil suitable for NBR and FKM seal Phosphate ester for FKM seal	
Fluid temperature range	°C	-30 to +80 (NBR seal) -20 to +80 (FKM seal)	
Viscosity range	mm <sup>2</sup> /s	10 to 800	
Degree of contamination		Maximum permissible degree of fluid contamination: Class 9. NAS 1638 or 20/18/15, ISO4406	
Max. operating pressure	bar	to 315	
Max. adjustable pressure	bar	50;100;200;315	
Max. flow-rate	L/min	100	
Weight	Type ZDB10	kg	Approx.2.7
	Type Z2DB10	kg	Approx.3.1

## Characteristic curves (Measured at $\vartheta_{oil} = 40^{\circ}C \pm 5^{\circ}C$ , using HLP46)

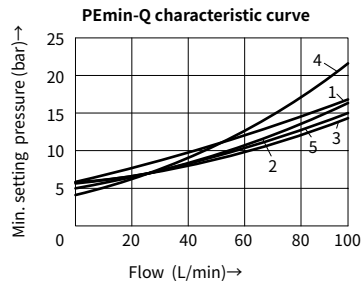
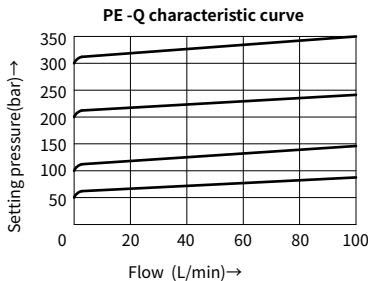

**The curves were measured at zero back pressure.**

- 1. VD(A to B)      3. VB and VC
- 2. VA              4. VP and VD(B to A)

## Unit dimensions

(Dimensions in mm)

Type ZDB10VA...L4X/..

Type ZDB10VP...L4X/..

Type ZDB10VT...L4X/..

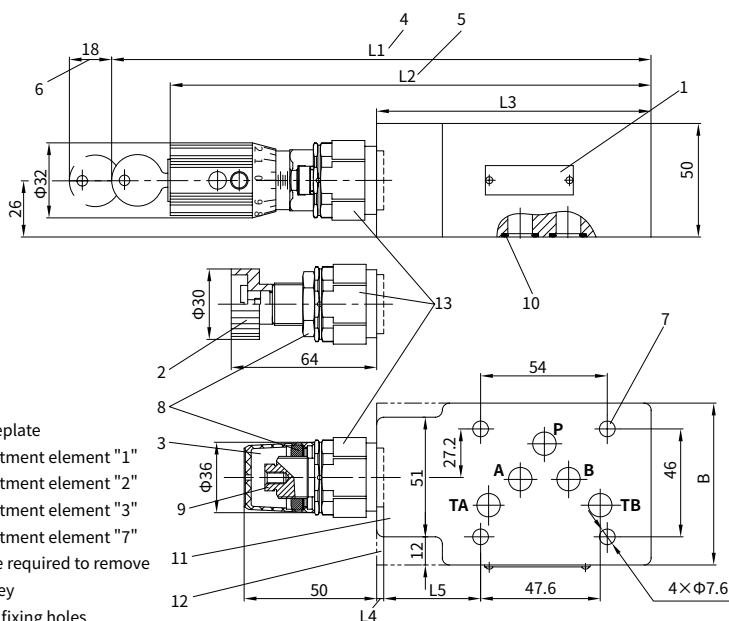

- 1 Nameplate
  - 2 Adjustment element "1"
  - 3 Adjustment element "2"
  - 4 Adjustment element "3"
  - 5 Adjustment element "7"
  - 6 Space required to remove the key
  - 7 Valve fixing holes
  - 8 Lockable nut S=24
  - 9 External hexagon screw S=10
  - 10 O-ring 12x2 (A2,B2,P2,TA2,TB2)
  - 11 Type ZDB10 VA and VP version
  - 12 Type ZDB10 VT version
  - 13 External hexagon S=30
- Tightening torque  $M_A=50\text{Nm}$

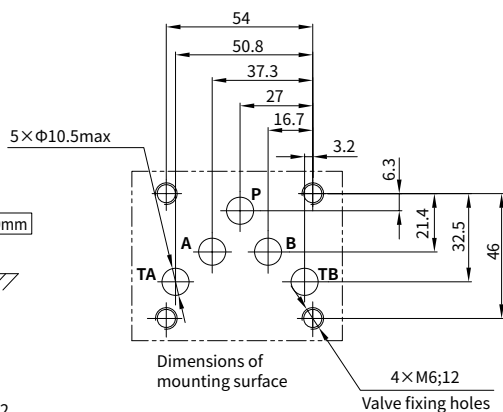
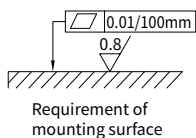
**Valve fixing screws:**

M6 internal hexagon screw or LT 30.02 double-screw bolt with LT 30.01 nut GB/T 70.1-10.9, the length according to sandwich, tightening torque  $M_A=15.5\text{ Nm}$ , must be ordered separately.

Type	B	L1	L2	L3	L4	L5
VA and VP	69	230	205	117	4	40.5
VT	70	218	193	105	2	27.8

# Unit dimensions

(Dimensions in mm)

## Type ZDB10VB...L4X/...

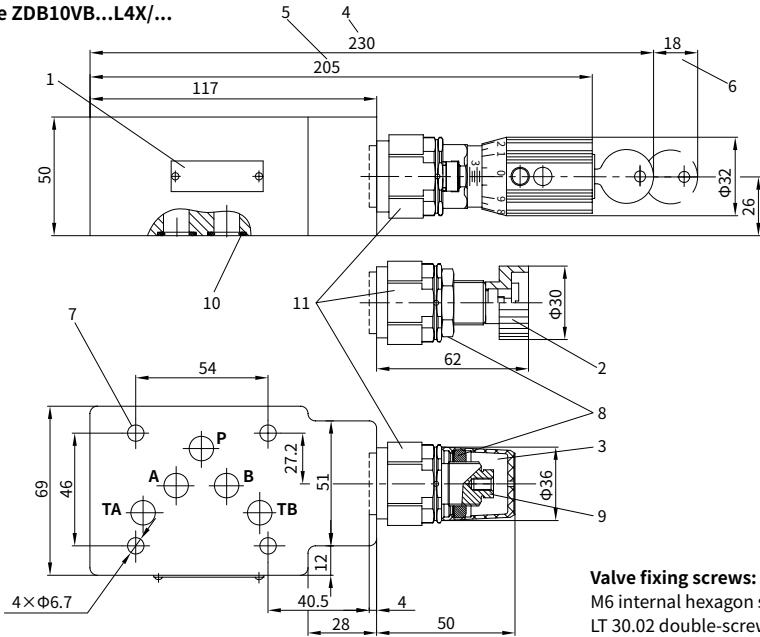

**Valve fixing screws:**  
 M6 internal hexagon screw or  
 LT 30.02 double-screw bolt  
 with LT 30.01 nut  
 GB/T 70.1-10.9, the length  
 according to sandwich,  
 tightening torque  $M_A=15.5\text{ Nm}$ ,  
 must be ordered separately.

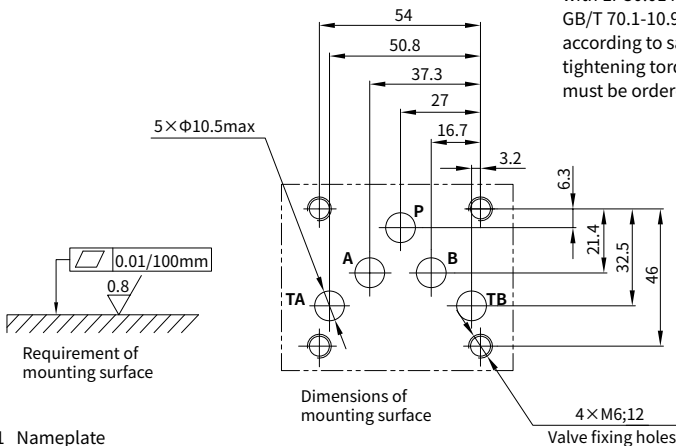

- 1 Nameplate
- 2 Adjustment element "1"
- 3 Adjustment element "2"
- 4 Adjustment element "3"
- 5 Adjustment element "7"
- 6 Space required to remove the key
- 7 Valve fixing holes

- 8 Lockable nut S=24
  - 9 External hexagon screw S=10
  - 10 O-ring 12x2 (A2,B2,P2,TA2,TB2)
  - 11 External hexagon S=30
- Tightening torque  $M_A=50\text{ Nm}$

## Unit dimensions

(Dimensions in mm)

Type Z2DB10VC...L4X/..

Type Z2DB10VD...L4X/..

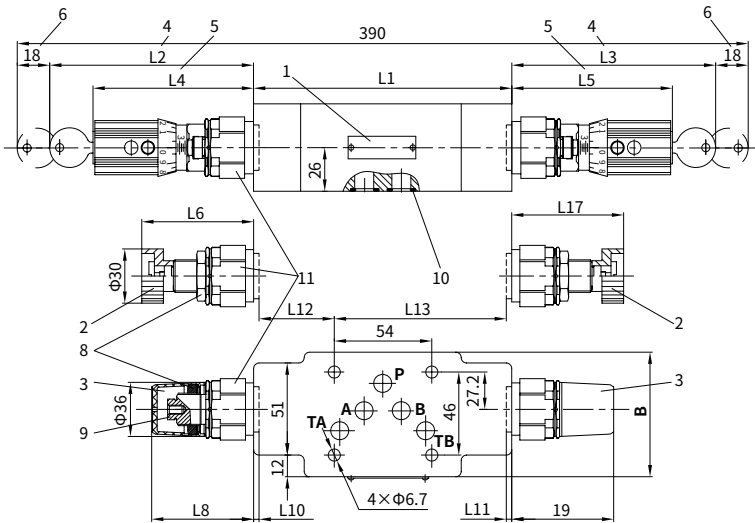

- 1 Nameplate
- 2 Adjustment element "1"
- 3 Adjustment element "2"
- 4 Adjustment element "3"
- 5 Adjustment element "7"
- 6 Space required to remove the key
- 7 Valve fixing holes
- 8 Lockable nut S=24
- 9 External hexagon bolt S=10
- 10 O-ring 12×2 (A2,B2,P2,TA2,TB2)
- 11 External hexagon S=30  
Tightening torque  $M_A=50$  Nm

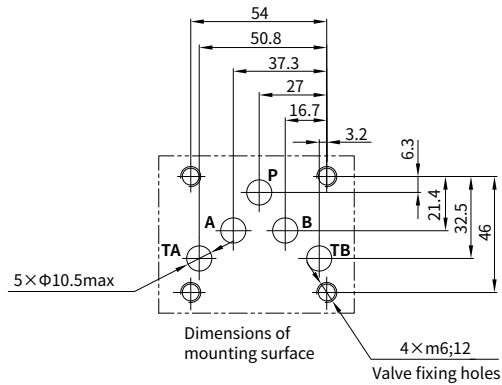

### Valve fixing screws:

M6 internal hexagon screw or LT 30.02 double-screw bolt with LT 30.03 nut GB/T 70.1-10.9, the length according to sandwich, tightening torque  $M_A=15.5$  Nm, must be ordered separately.

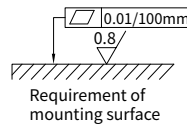

Type	B	L1	L2	L3	L4	L5	L6	L7	L8	L9	L10	L11	L12	L13
VC	69	123	115	116	90	91	64	65	52	53	2	1	32.5	87.5
VD	70	132	111	111	86	86	60	60	48	48	6	6	33	87