



6.4

Proportional pressure reducing valve

Type DRE(E)/ DREM(E)...30

Sizes 10 , 25 and 32
Up to 315 bar
Up to 300 L/min

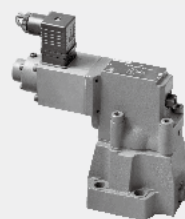

Contents

Function and configuration	02
Symbols	03
Ordering code	03
Technical data	04
Electrical data	04
Characteristic curves	05
Unit dimensions	06-07

Features

- For sub-plate mounting:
- Porting pattern to DIN 24 340 form D and ISO 5781
- For installation in manifolds
- 4 pressure ratings
- Maximum pressure limitation, optional
- Digital amplifier type VT-2000 of modular design (must be ordered separately)

Function and configuration

The valve types DRE/DREM are pilot operated pressure reducing valves. They are used for pressure reduction . The valves consist of the pilot valve (1) with proportional solenoid (2), main valve (3) with main spool assembly (4), as well as an optional check valve (5).

Type DRE10...

The setting of the pressure in port A is dependent on the voltage present at the proportional solenoids (2). At static, proportional solenoids (2) breakaway, the connection from B to A opens and fluid can flow freely from Port B to port A via main spool (4). When valve works, pressure fluid from port A acts on the spring load side of the main spool (4) via pilot valve with throttle (6), (7) and (8), and at the same time acts on spool (10) effected by electromagnetic force. If pressure at port A exceeds the preset value of the corresponding proportional solenoid (2) , then the spool (10) opens. Signal and pilot fluid is from port A, and fluid flows to tank through spool (10) and port Y . There is pressure

differential on main spool (4) which makes itself into controller position and keeps flow constant pressure in port A as same as the setting value of the proportional solenoids (2). If the pressure in the port A increases and the main spool (4) is closed, little fluid will flow to tank via hole (9) and port Y. In order to allow free-flow from port A to B a check valve (5) can be fitted.

Type DRE20...and DRE30...

Same principle with DRE10 in function and pilot oil drains out from channel (9) and port B. There is a flow control valve (11) fixed in the pilot valve (1) to relieve the pilot oil. And the overload protector (12) in the port A can prevent the pressure from abnormally high when flow Q=0.

Type DREM...

A spring loaded pressure relief valve (13) can be optionally installed to prevent higher pressure in port A caused by abnormal peak voltage of proportional solenoids.

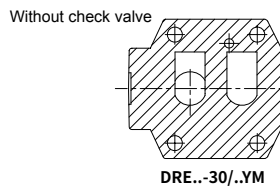
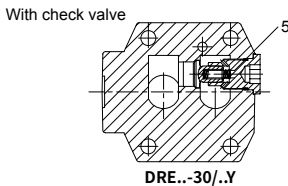
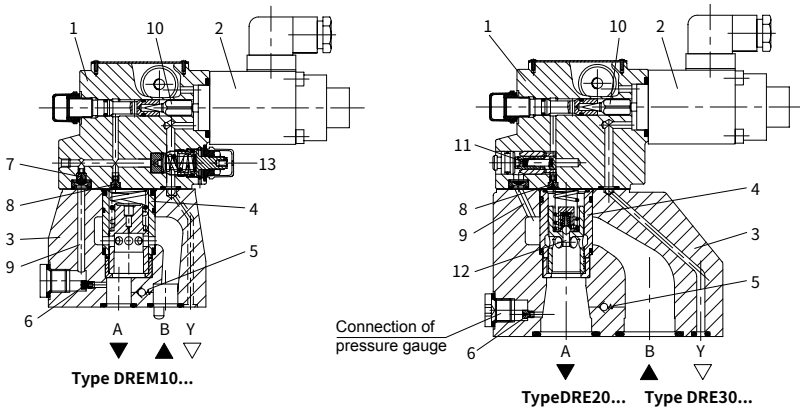

Symbols

10
DRE20-30/...YM
30
DRE CN10-30/...Y
DRE CN30-30/...Y

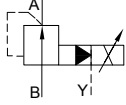

10
DREM20-30/...YM
30
DREM CN 10-30/...Y
DREM CN 30-30/...Y

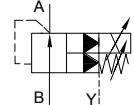

10
DRE20-30/...Y
30

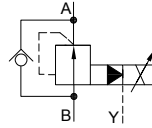

10
DREM20-30/...Y
30

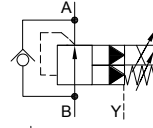

DRECN^N_H-30/..



DREMCN^N_H-30/..



Ordering code



Without maximum pressure safety	=No code
With maximum pressure safety = M	
Pilot operated	= No code
Pilot operated valve for size 10 (do not enter nom. size)	= CN
Pilot operated valve for size 20 and 30 (do not enter nom. size)	= CH
Pilot operated valve with main spool assembly for size 10 (enter nom. size 10)	= CN
Pilot operated valve with main spool assembly for size 30 (enter nom. size 30)	= CH
For external control electronics	=No code
With integrated electronics (OBE)	=E
Nominal size 10	= 10
Nominal size 25	= 20
Nominal size 32	= 30
Series 30	= 30
Max. pressure 50 bar	= 50
Max. pressure 100 bar	= 100
Max. pressure 200 bar	= 200
Max. pressure 315 bar	= 315

Further information in plain text	
V =	FKM seals
No code =	NBR seals
Pilot oil drain port Y	
No code =	Inch threaded
2 =	Metric threaded
For type DRE(M)E:	
A1=	Command/actual value 0 to 10V
F1=	Command/actual value 4 to 20 mA
For type DRE(M) :	
K4=	Without plug-in connector
Z4=	With plug-in connector
For type DRE(M)E:	
K31=	Without plug-in connector
Z31=	With plug-in connector
For type DBE(M)E, Supply voltage	
G24=	+ 24 V DC
No code=	Without check valve
M =	With check valve
Y=	Pilot oil drain always external, separate and zero pressure to the tank

06

Technical data

Fluid		Mineral oil suitable for NBR and FKM seal Phosphate ester for FKM seal		
Fluid temperature range		°C	-30 to +80 (NBR seal) -20 to +80 (FKM seal)	
Viscosity range		mm ² /s	2.8 to 380	
Degree of contamination		Maximum permissible degree of fluid contamination: Class 9. NAS 1638 or 20/18/15, ISO4406		
Max. operating pressure	Port A, B	bar	315	
	Port Y		Back to tank with zero pressure	
Max. setting pressure	Port A	bar	50; 100; 200; 315	
Min. setting pressure	Port A		Dependent with Q, see characteristic curves	
Pressure at current value 0 in port A		=Min. settable pressure (see characteristic curves)		
Max. pressure limitation (stepless)	Setting pressure		setting range under max. pressure limitation	
	50 bar		10-60 ⁺²⁰ bar	
	100 bar		10-120 ⁺²⁰ bar	
	200 bar		10-220 ⁺²⁰ bar	
	315 bar		10-340 ⁺²⁰ bar	
Max. pressure limitation setting range	When rated pressure=50 bar, between 60~80 bar			
	When rated pressure=100 bar, between 120~140 bar			
	When rated pressure=200 bar, between 220~240 bar			
	When rated pressure=315 bar, between 340~360 bar			
Nominal size		10	25	32
Max. flow-rate	L/min	80	200	300
Pilot flow-rate (for pilot valve)	L/min	0.7 to 2		
Linearity		±3.5%		
Repeatability		<±2%		
Magnetic creeping	with shimmy		without shimmy	
	±2.5% P max (200Hz, amplitude 200mAss)		±4.5% P max	
Shifting time	100 to 300ms (dependent with the system)			

Electrical data

Supply voltage		DC
Min. solenoid current	mA	100
Max. solenoid current	mA	800
Coil resistance		19.5Ω at 20°C, Max. warm value :28.8Ω
Working status		Continuous
Max. working environmental temperature		+50°C
Electrical connection		Plug-in connector to DIN EN 175301-803/ISO 4400
Valve protection to DIN 40 050		IP 65
Amplifier		VT2000

Characteristic curves (Measured at $\theta_{oil} = 40^{\circ}C \pm 5^{\circ}C$, using HLP46)

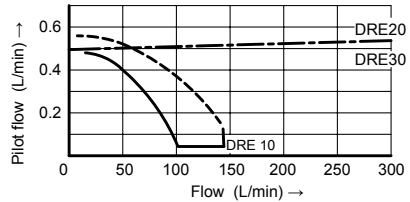
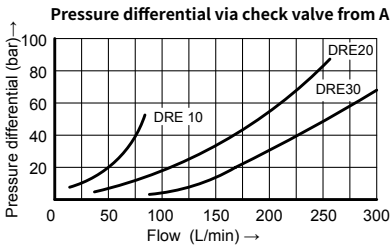
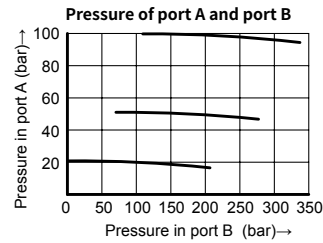
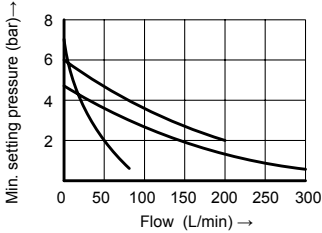
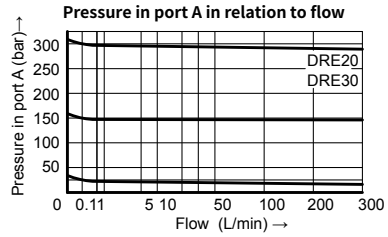
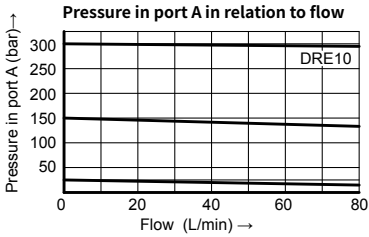

--- = 20bar ΔP DRE10
 — = 100bar ΔP DRE10
 - - - = 20bar and 100bar ΔP DRE20/30

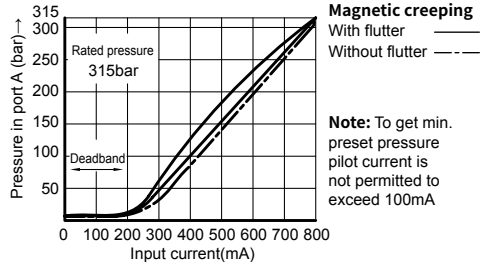
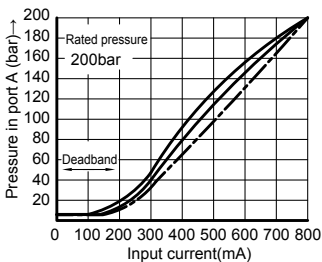
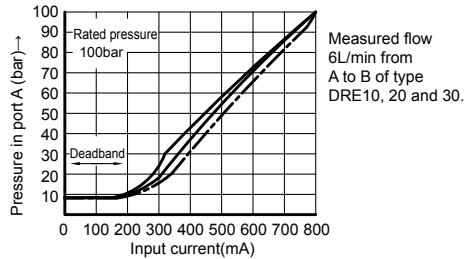
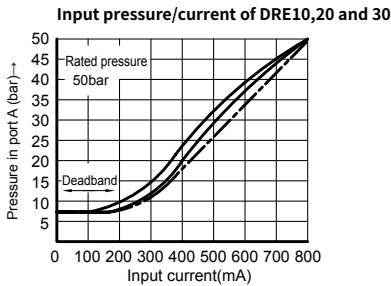

Unit dimensions

(Dimensions in mm)

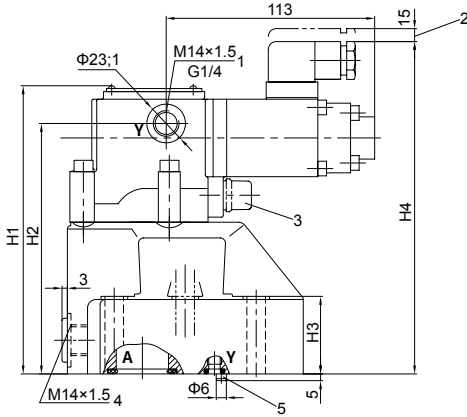

- 1 As supplied, this port is plugged.
After removal of this plug this port can also be used as an external pilot oil drain.
- 2 Space required to remove plug-in connector.
- 3 Max. pressure limitation
(its application see hereinbefore "note")
- 4 Port X used for remote controlling the DRE10 and pressure gauge connection on DRE20 and DRE30
- 5 Locating pin
- 6 Name plate
- 7 Pilot oil drain always external and separate to tank at zero pressure.
- 8 Dead hole
- 9 Valve fixing screw holes
4 (DRE10 and 20); 6 (DRE30)

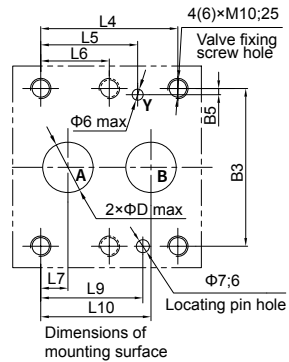
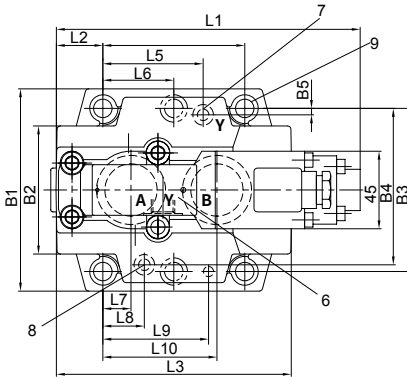

Valve fixing screws:

Internal hexagon screw GB/T 70.1-10.9,

DRE10:M10×50, DRE20:M10×60

DRE10:M10×70

Tightening torque, $M_A = 75 \text{ Nm}$

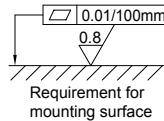

Size	B1	B2	B3	B4	B5	O-ring (port A and B)	O-ring (port X and Y)	D	H4					
10	85	50	66.7	58.8	7.9	17.12×2.62	9.25×1.78	13	188					
25	102	59.5	79.4	73	6.4	28.17×3.53	9.25×1.78	22	198					
32	120	76	96.8	92.8	3.8	34.52×3.53	9.25×1.78	30	206					
Size	L1	L2	L3	L4	L5	L6	L7	L8	L9	L10	H1	H2	H3	Weight
10	181	35.5	96	42.9	21.5	-	7.2	21.5	31.8	35.8	152	136.5	28	5.2kg
25	177	33.5	112	60.3	39.7	-	11.1	20.6	44.5	49.2	162	146.5	38	6.3kg
32	176.5	28	140	84.2	59.5	42.1	16.7	24.6	62.7	67.5	170	154.5	46	8.6kg

Unit dimensions

(Dimensions in mm)

Insert cartridge valve

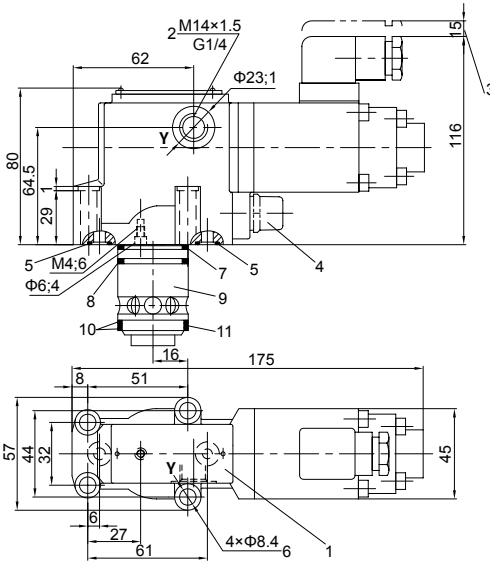

- 1 Name plate
- 2 (Port Y) pilot oil drain always external and separate to tank at zero pressure.
- 3 Space required to remove plug-in connector.
- 4 Max. pressure limitation (its application see hereinbefore "note")
- 5 O-ring 9.25×1.78
- 6 Valve fixing screw hole
- 7 O-ring 28×2.65
- 8 O-ring 28×1.8
- 9 Main spool assembly
- 10 Retaining ring 28.4×32×0.8
- 11 O-ring 27.3×2.4
- 12 Retaining ring and O-ring should be fixed onto the hole before fixing the main spool.
- 13 The throttle in the DREC10 must be ordered separately; and the cartridge assembly includes the main spool and throttle.
- 14 Cannelure's diameter D2 can meet hole diameter D3, but must pay attention don't damage the port and the valve fixing holes.
- 15 Pilot lines of DRE CH20 and DRE CH30.
- 16 Pilot lines of DRE CH10.

Size	D1	D2	D3	Main spool assembly ordering code		Valve fixing screws	Tightening torque	Weight
10	10	40	10	306 727	306 728	4pcs M8×40 GB/T70.1-10.9 Internal hexagon screw	20Nm	3kg
25	20	45	20	306 729	306 730			
32	30	45	30	(NBR)	(FKM)			

